

KVX 3.100

Rotary vane vacuum pumps

- oil-free and air-cooled
- incl. integrated suction filter, vacuum regulating valve and integrated blow off valve

Drehschieber-Vakuumpumpen

- trockenlaufend und luftgekühlt
- inkl. integriertem Ansaugfilter, Vakuumregulierventil und integriertem Abblaseventil

Pompes à vide à palettes

- fonctionnant à sec et refroidies par air
- incl. filtre d'aspiration intégré, soupape de reglage vide et soupape d'échappement intégré

Pompe per vuoto a palette

- funzionanti a secco e raffreddate ad aria
- incl. filtro di aspirazione integrato, valvola regolazione vuoto e valvola di sfianto integrato

Bombas de vacío de paletas

- sin aceite y refrigerado por aire
- incl. filtro de aspiración integrado, válvula reguladora de vacío y válvula de escape integrado



fig.: KVX 3.80

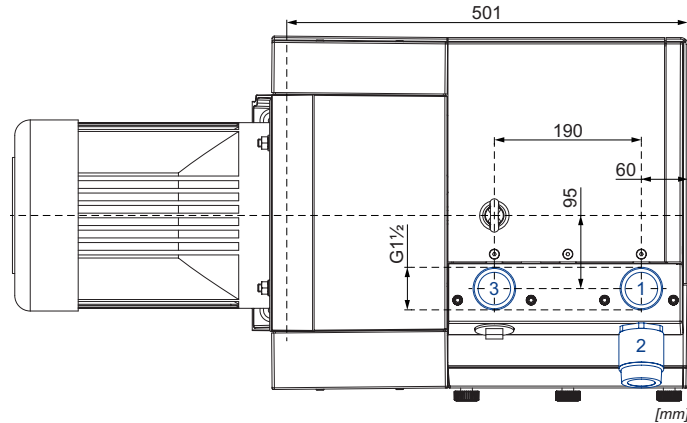
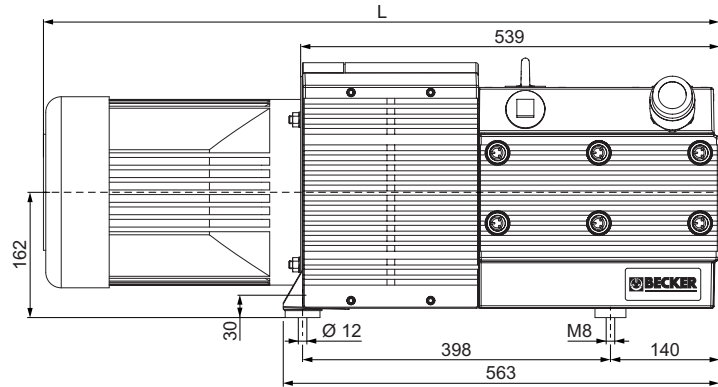
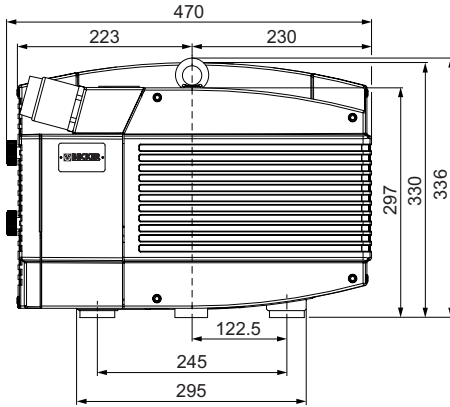

- Vacuum connection
Sauganschluss
Raccord vide
Raccordo aspirazione
Conexión de vacío
- Vacuum regulating valve
Vakuumregulierventil
Soupape de reglage vide
Valvola regolazione vuoto
Válvula reguladora de vacío
- KVX 3.100/0-54**
Exhaust air connection
Abluftanschluss
Raccord échappement d'air
Raccordo scarico aria
Conexión aire residual

m³/h		mbar abs. ¹⁾		kW 3~		kg	dB(A) ²⁾	
50 Hz	60 Hz	50 Hz	60 Hz	50 Hz	60 Hz		50 Hz	60 Hz
98	112	100	100	3.0	3.6	71 + (M)	75	77

(M)	kW		V ±10%		min ⁻¹		A		kg	no.	L	no. KVX + (M)		
	50 Hz	60 Hz	50 Hz	60 Hz	50 Hz	60 Hz	50 Hz	60 Hz						
	3.0	3.6	Δ 230 / Y 400 IE2	Δ 265 / Y 460 IE2	Δ 230 / Y 400	1435	1720	11.1/6.4	10.9/6.3	11.77/6.81	29	42479422300003RE	843	G017169
	-	3.6	-	YY 230 / Y 460 IE2 + UL/CSA	usable @ 208	-	1740	-	13.4/6.7	14.3	31.5	42579407300114TA	793	G017975
	3.0	3.6	Δ 200 / Y 350	Δ 220 / Y 380-400 IE2	Δ 200 / Y 350	1425	1720	13.5/8	13.3/7.7-7.3	14.6/8.4	29	42479453300003RE	843	G017976
	-	3.6	-	Δ 400 / Y 690 IE2	-	-	1720	-	7.8/4.6	-	29	42579454300003RE	843	G017974

- | | | | | |
|--|--|--|--|---|
| 1) mbar absolute | mbar absolut | mbar absolu | mbar assoluto | mbar absolutos |
| 2) DIN EN ISO 3744 (KpA = 3 dB(A)) interval of 1m, at medium load, both connection sides piped | DIN EN ISO 3744 (KpA = 3 dB(A)) Abstand von 1m, bei mittlerer Belastung, beide Seiten abgeleitet | DIN EN ISO 3744 (KpA = 3 dB(A)) intervalle de 1m, à régime moyen, avec dérivation des deux côtés | DIN EN ISO 3744 (KpA = 3 dB(A)) intervallo di 1m, a medio regime, entrambi i lati derivati | DIN EN ISO 3744 (KpA = 3 dB(A)) intervalo de 1m, en media carga, derivados de ambos lados |
| ▪ Dimensions in mm | Maßangaben in mm | Mesures en mm | Misure in mm | Dimensiones en mm |

Suction air rate • Saugluftmenge • Débit d'air aspiré • Volume d'aria aspirata • Volumen de aire aspirado

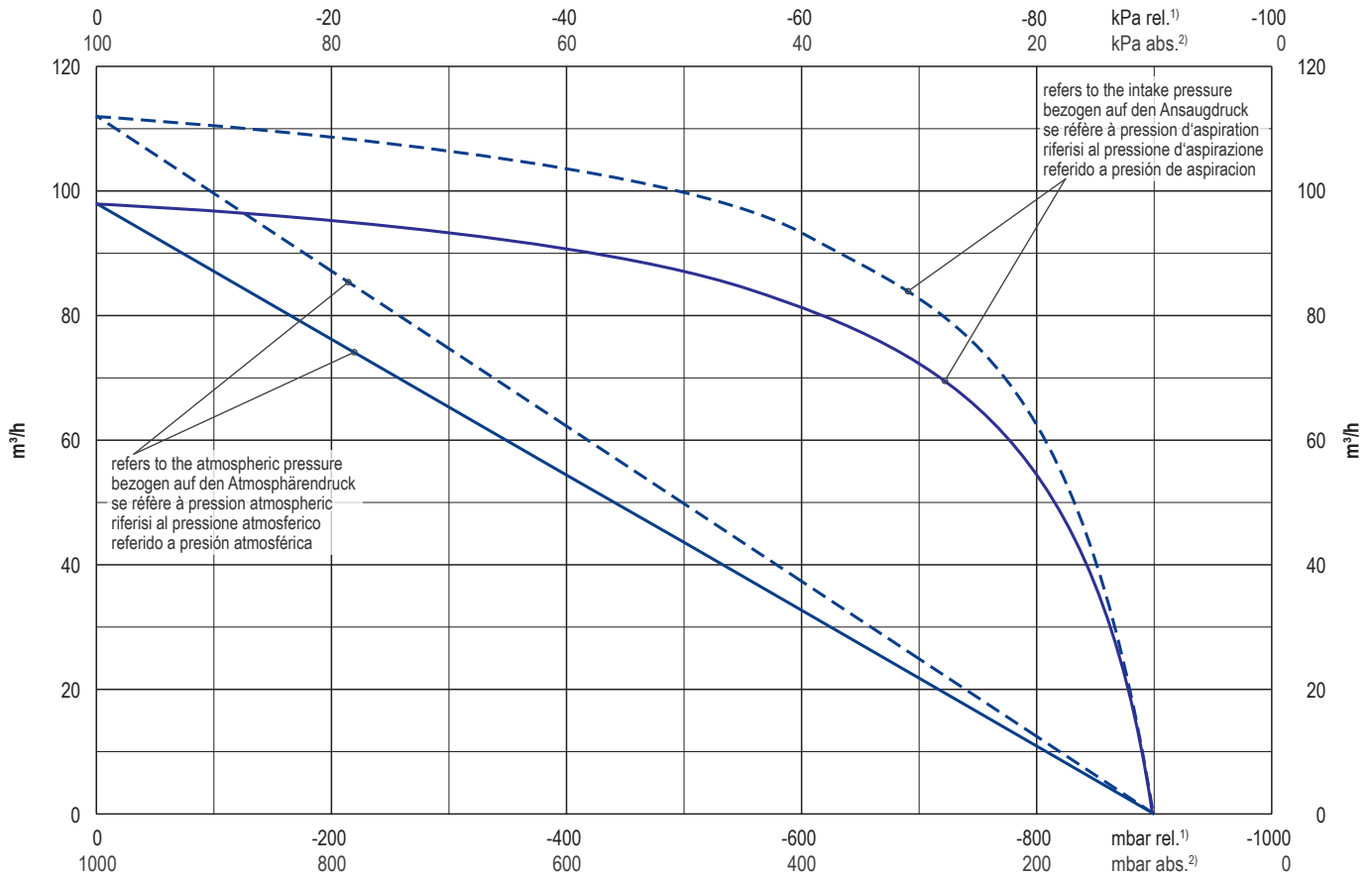

Exhaust air temperature • Ablufttemperatur • Température d'air à l'échappement
Temperatura dell'aria scarica • Temperatura del aire de escape

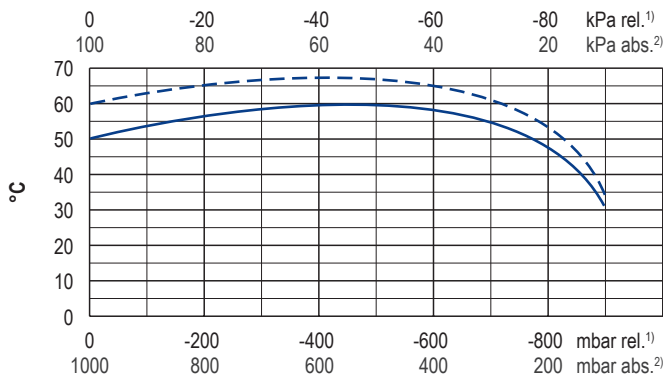

Motor shaft power • Wellenleistung • Puissance du moteur axe
Potenza del motore albero • Capacidad de eje del motor

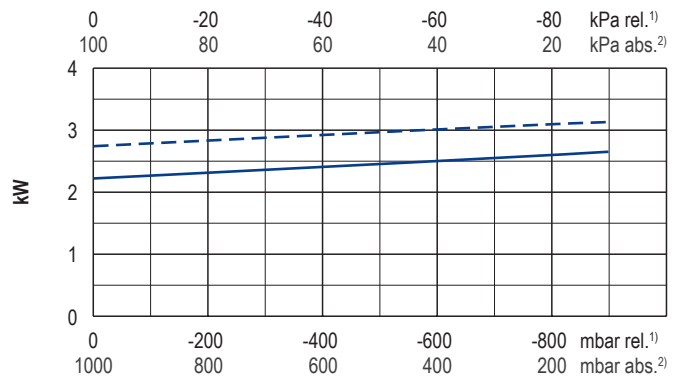

— 50 Hz
- - - 60 Hz

1) relative relativ relatif relativo relativa
2) absolute absolut absolu assoluto assoluta

• Reference data Bezugsdaten Référence Riferimento Referencia 1000 mbar, 20°C
• Tolerance Toleranz Tolérance Tolleranza Tolerancia ±5%

i	Variants	Varianten	Variantes	Varianti	Variantes
KVX 3.100/0-54	With exhaust air connection	Mit Abluftanschluss	Avec raccord échappement d'air	Con raccordo scarico aria	Con conexión aire residual
KVX 3.100 (SH 13)	In sound proof box SH 13	In Schallhaube SH 13	Dans caisse d'insonorisation SH 13	In casse insonorizzanti SH 13	En caja a prueba de sonido SH 13
KVX 3.100/0-400	VARIAIR Unit with frequency inverter	VARIAIR Unit mit Frequenzumrichter	VARIAIR Unit avec convertisseur de fréquence	VARIAIR Unit con convertitore di frequenza	VARIAIR Unit con variador de frecuencia
KVT 3.100	Standard pump	Standardpumpe	Pompe standard	Pompa standard	Bomba estándar
	Performance data / dimensions can differ Combinations on request	Leistungsdaten / Abmessungen können abweichen Kombinationen auf Anfrage	Données de performance / mesures peuvent différer Combinaisons sur demande	Dati di performance / misure possono differire Combinazioni su richiesta	Datos de rendimiento / dimensiones pueden diferir Combinaciones a petición